

Relação do aço

AÇO	N	DIAM (mm)	QUANT	Relação do aço	
				C.UNIT (cm)	C.TOTAL (cm)
CA60	1	5.0	80	96	7680
	2	5.0	24	39	936
CA50	3	8.0	4	145	580
	4	8.0	14	292	4088
	5	8.0	36	111	3996
	6	8.0	32	121	3872
	7	10.0	4	291	1164
	8	10.0	12	110	1320
	9	10.0	8	108	864
	10	10.0	29	276	8004
	11	12.5	4	354	1416

Resumo do aço

AÇO	DIAM (mm)	C.TOTAL (m)	PESO + 10 % (kg)
CA50	8.0	125.4	54.4
	10.0	113.6	77
CA60	12.5	14.2	15
	5.0	86.2	14.6
PESO TOTAL (kg)			
CA50		146.4	
CA60		14.6	

Volume de concreto (C-30) = 2.71 m³  
Área de forma = 18.29 m²

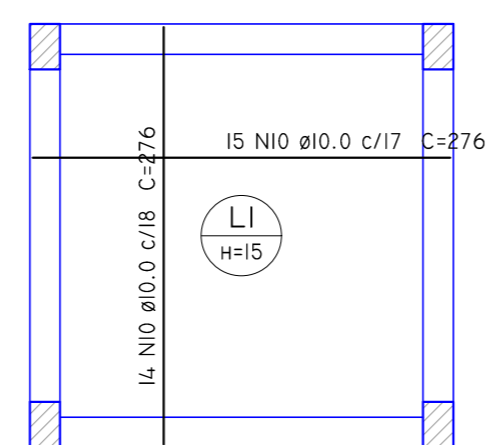
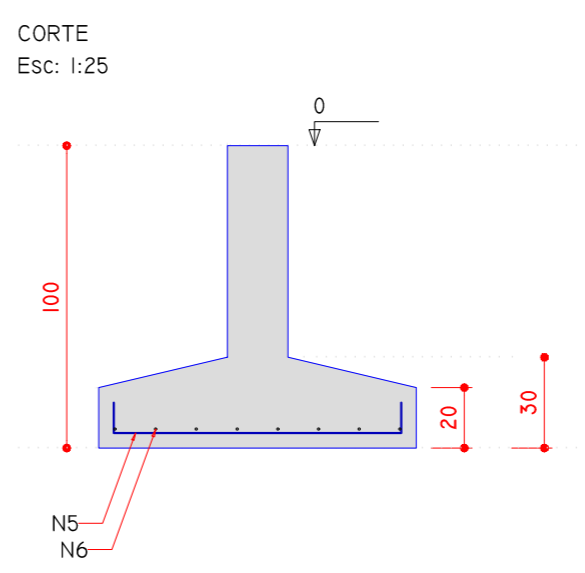
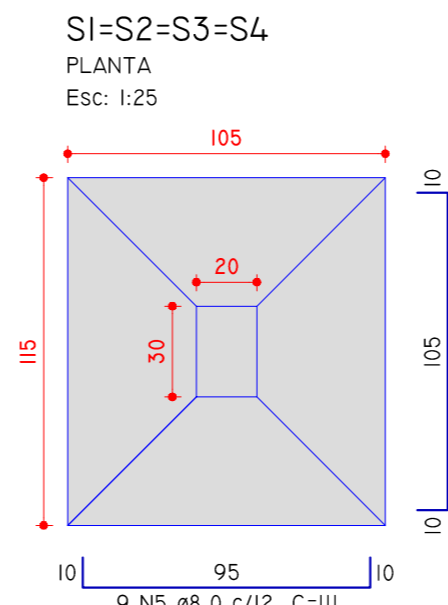
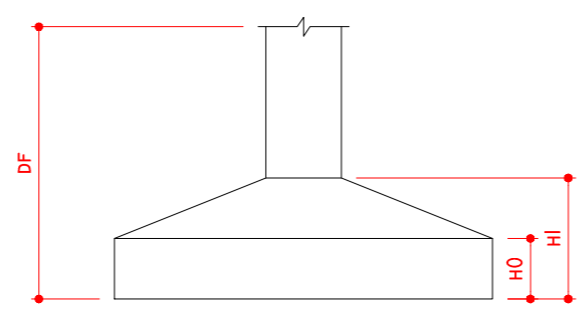
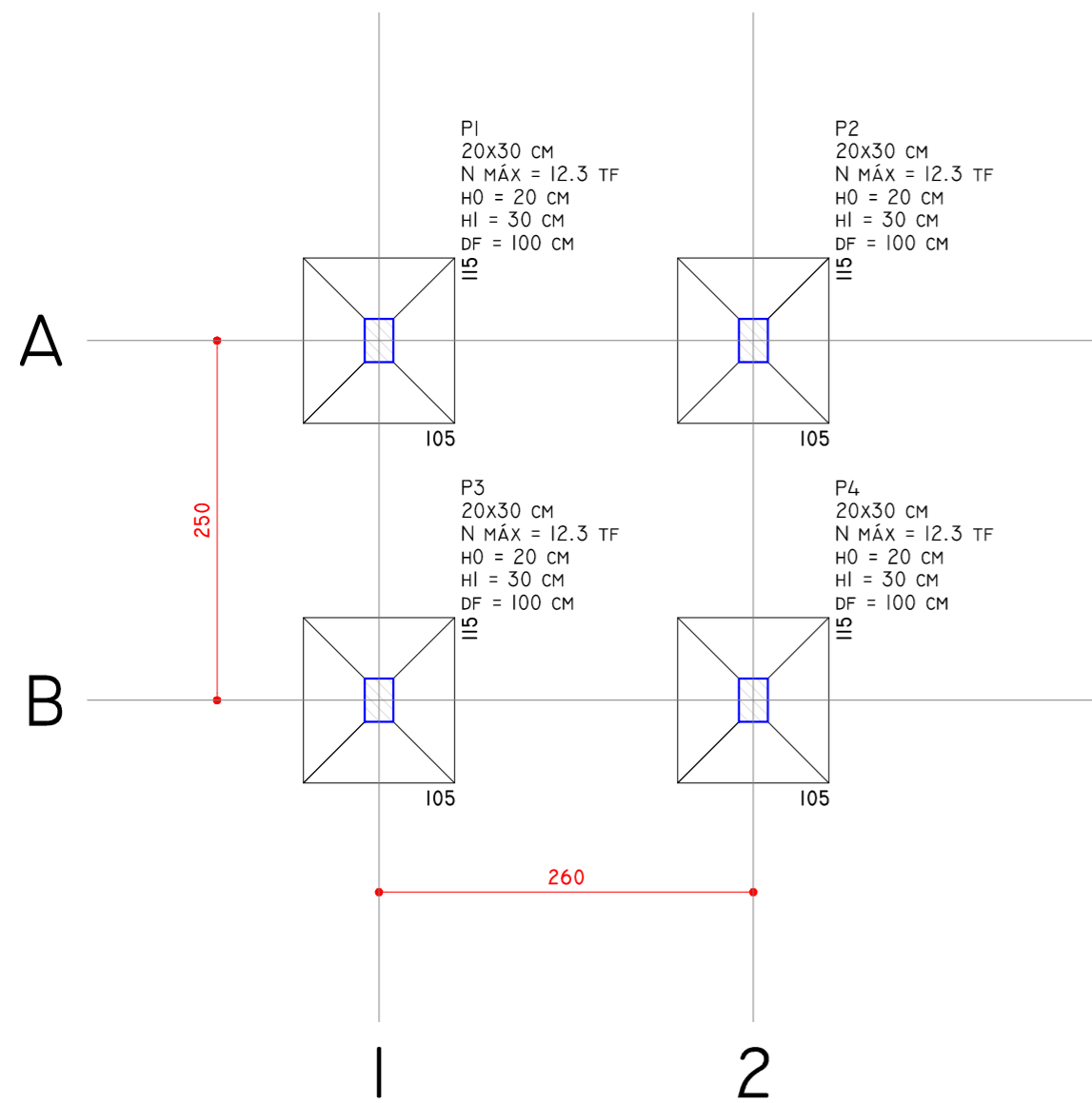

ARMADURA POSITIVA DAS LAJES DO PAVIMENTO BASE

Esc: 1:50

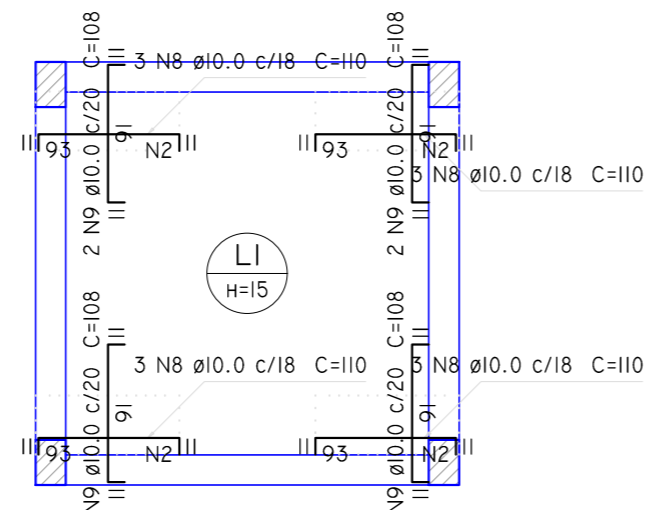

ARMADURAS DE DISTRIBUIÇÃO	
ARMADURA	ARMADURA DE DISTRIBUIÇÃO
N8	6 N2 ø5.0 c/17 C=39
N8	6 N2 ø5.0 c/17 C=39
N8	6 N2 ø5.0 c/17 C=39
N8	6 N2 ø5.0 c/17 C=39

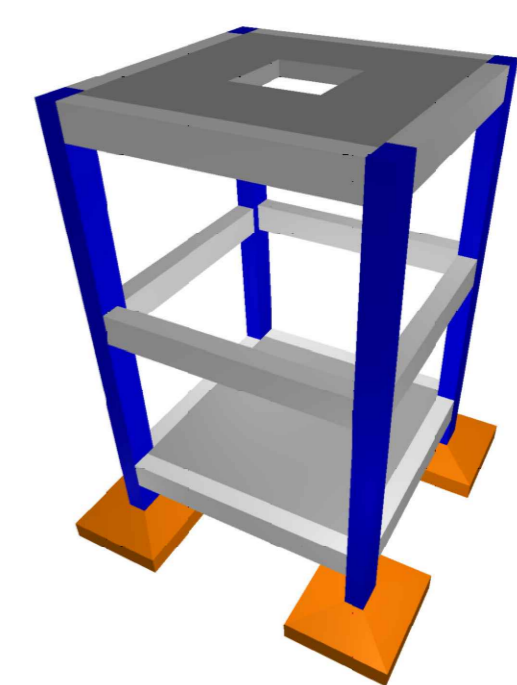

3D - CISTERNA

SEM ESCALA

CARACTERÍSTICAS DOS MATERIAIS		
FCK (KGF/CM²)	ECS (KGF/CM²)	ABATIMENTO (CM)
300	268384	16.00

PLANTA DE LOCAÇÃO

Esc: 1:50

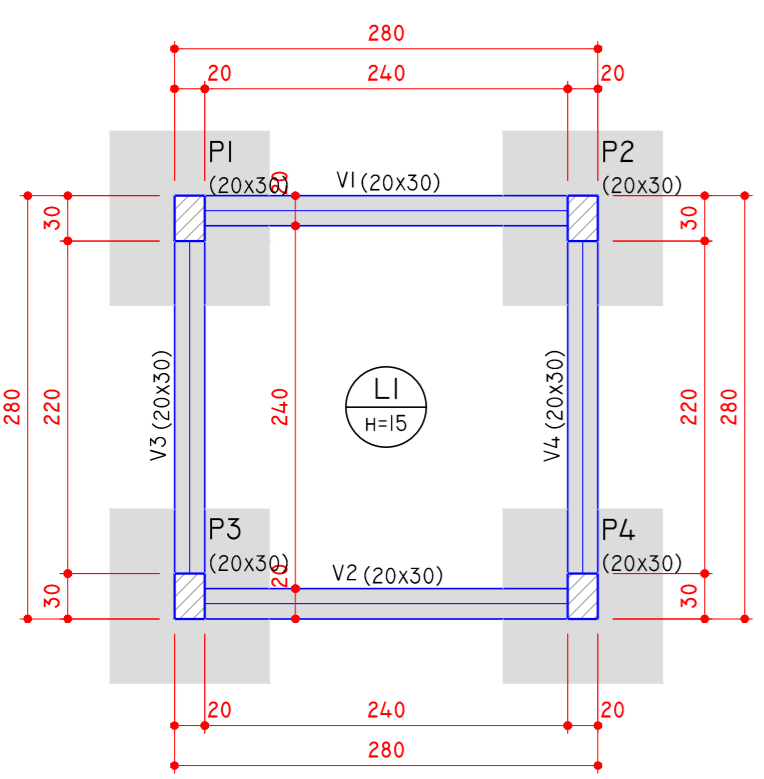

FORMA DO PAVIMENTO BASE (NÍVEL 0)

Esc: 1:50

V1 (20 x 30)

Esc: 1:50

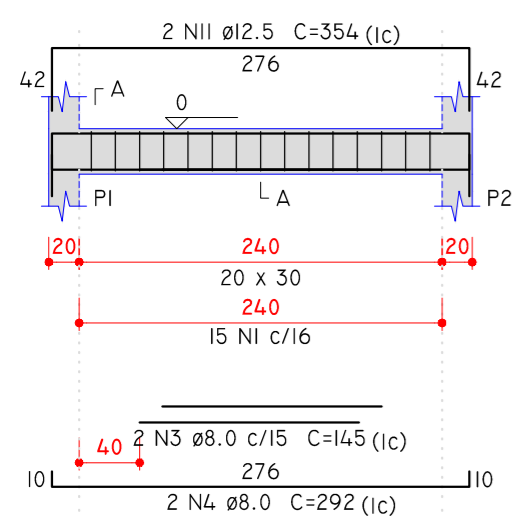

SEÇÃO A-A V2 (20 x 30)

Esc: 1:15

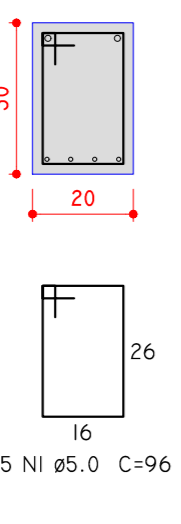

V2 (20 x 30)

Esc: 1:50

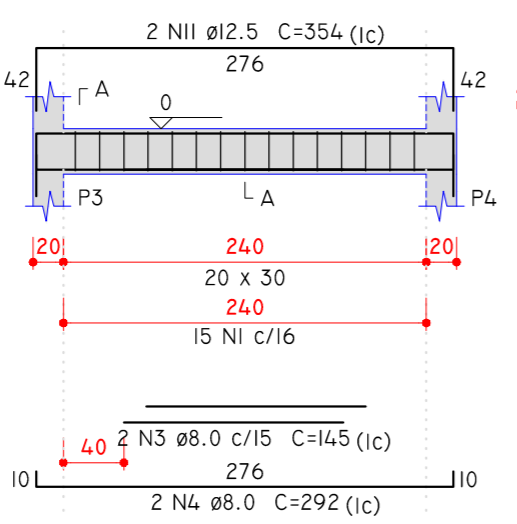

SEÇÃO A-A V3 (20 x 30)

Esc: 1:15

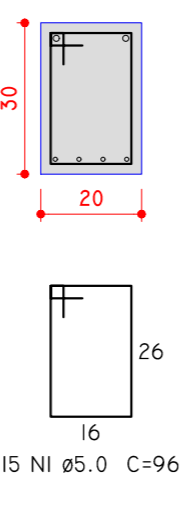

V3 (20 x 30)

Esc: 1:50

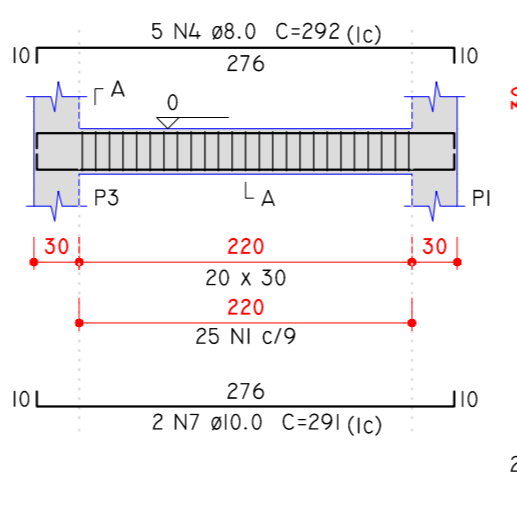

SEÇÃO A-A V4 (20 x 30)

Esc: 1:15

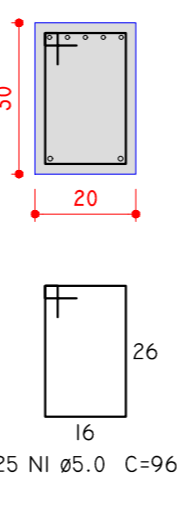

V4 (20 x 30)

Esc: 1:50

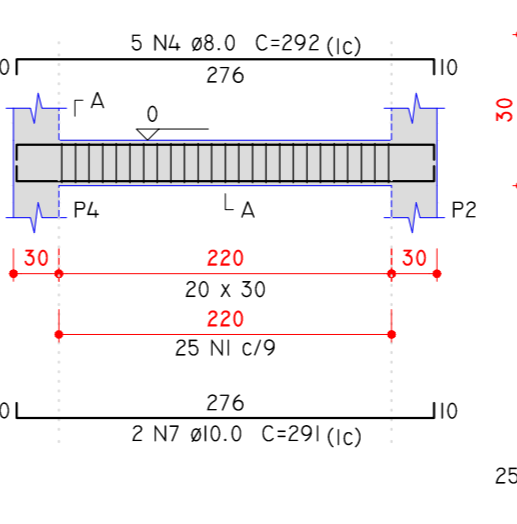

SEÇÃO A-A

Esc: 1:15

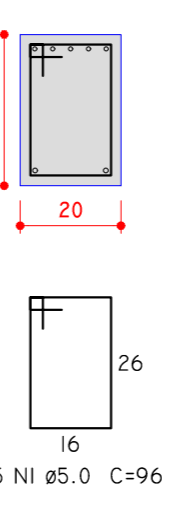

LEGENDA DOS PILARES		LEGENDA DAS VIGAS E PAREDES	
[Symbol]	PILAR QUE PASSA	[Symbol]	VIGA



**ALGETEC ENGENHARIA E CONSTRUÇÃO**  
Rua João Pessoa, 880 - sl B - Santa Terezinha  
Pato Branco/PR  
46. 99102 2782  
www.algetec.eng.br

PROJETO ESTRUTURAL

Resp. Técnico	Eng. Civil Daniel Parcianello, CREA: 072040/D Eng. Civil André Mateus Canan, CREA: 193875/D Eng. Civil Loriane C. Parcianello, CREA: 172355/D	Proprietário	Município de Pato Branco - PR
End.	Rua Jaciretã Pato Branco/PR	Data	23/09/2021
Obra	Teatro Municipal Naura Rigon	Escala	Indicada
Referência	CISTERNA 1		

92  
93